

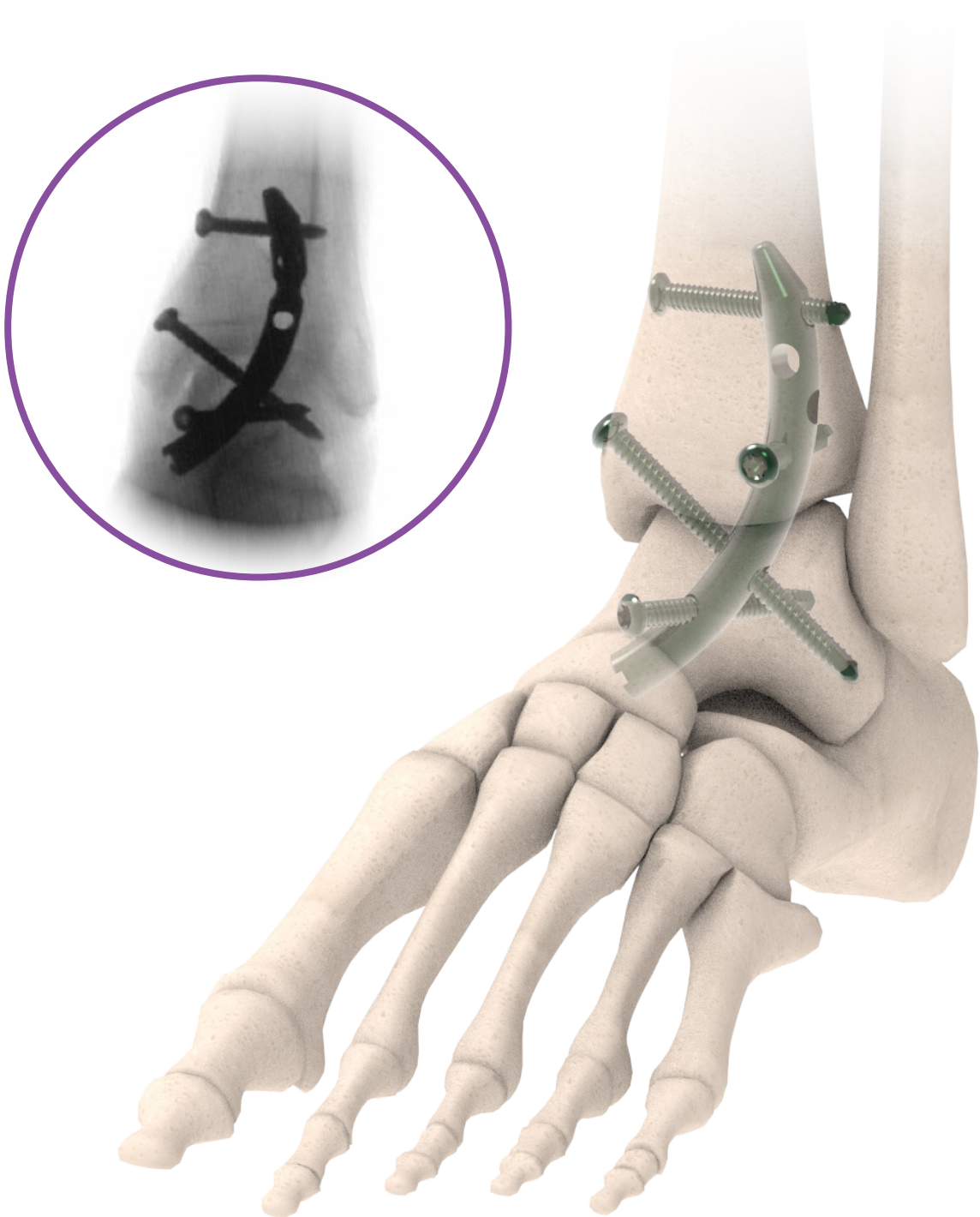

Shotel™ Ankle Arthrodesis Nail System

Surgical Technique





Contents

Product

The Shotel™ Ankle Arthrodesis Nail System is an intramedullary nail that provides compression and rigid fixation for primary ankle fusions. The unique curved design allows an approach through the medial side of the talus and achieves fusion at the tibiotalar joint while allowing unrestricted motion to remain at all other joints. The Shotel™ Ankle Arthrodesis Nail System is a load sharing intramedullary nail which may allow early weight bearing.

Table of Contents

Indications & Contraindications	1
Drill Guide Assembly	2
Surgical Technique	3-8
Postoperative X-rays	9
Instrument Kit	10
Ordering	11-12



Indications for Use & Contraindications

The Shotel™ Ankle Arthrodesis Nail System is intended for use for the following indications:

- Charcot Foot
- Avascular necrosis of the talus
- Failed total ankle arthroplasty
- Trauma (malunited tibial pilon fracture)
- Severe deformity or instability as a result of talipes equinovarus, cerebral vascular accident, paralysis or other neuromuscular disease
- Revision ankle arthrodesis
- Neuroarthropathy
- Rheumatoid arthritis
- Osteoarthritis
- Pseudoarthrosis
- Post-Traumatic arthrosis
- Previously infected arthrosis
- Severe end stage degenerative arthritis
- Severe defects after tumor resection
- Pantalar arthrodesis

Contraindications

- Dysvascular limb
- Active infection
- Severe longitudinal deformity
- Insufficient plantar heel pad
- Where an isolated ankle or subtalar fusion can be preformed
- Patient conditions including blood supply limitations and insufficient quantity and quality of bone
- Patients with mental or neurologic conditions who are unwilling or incapable of following postoperative care instructions
- Foreign body sensitivity. Where material sensitivity is suspected, testing is to be completed prior to implantation of the device

Possible Adverse Effects

- Loosening, bending, cracking, or fracture of the nail or screws or loss of fixation in bone attributable to nonunion
- Loss of anatomic position with nonunion or malunion with rotation or angulation
- Infection, both deep and superficial
- Allergies and other reaction to the device material

Drill Guide Assembly



1

Choose the appropriate drill guide (Left or Right)

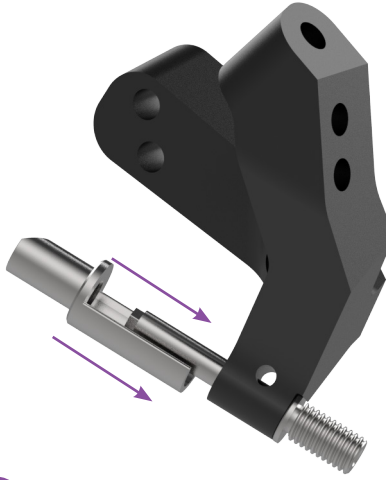

2

Slide the compression sleeve that corresponds with the drill guide over the non-threaded post.

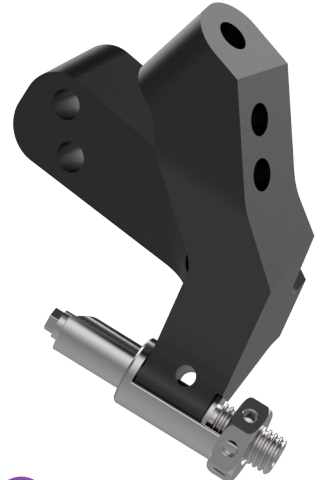

3

Thread the provided nut onto the threaded post. This will allow the compression sleeve to move up and down.

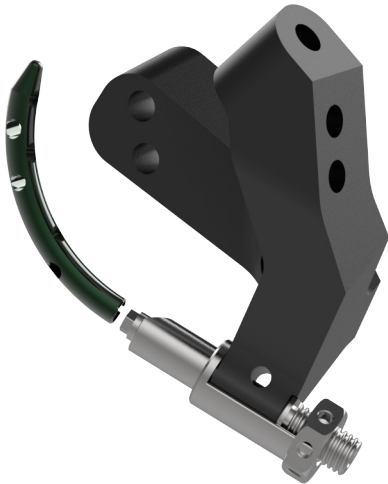

4

Insert the corresponding nail onto the drill guide. Ensure that the slot on the nail aligns with the slot on the drill guide.



5

Finally, insert the drill guide locking bolt through the cannulation and turn clockwise to secure the nail onto the drill guide.

Surgical Technique

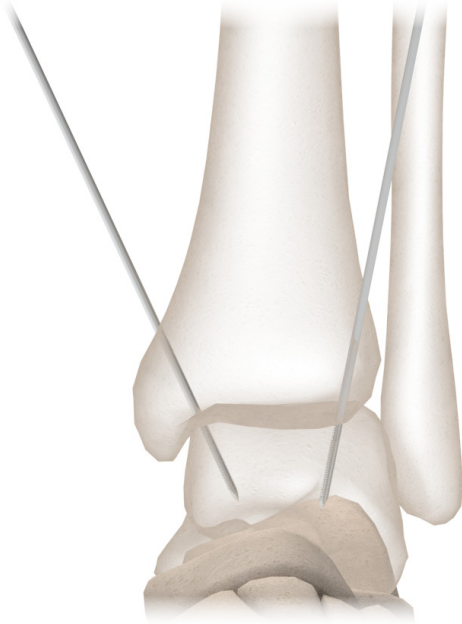

Figure 1a

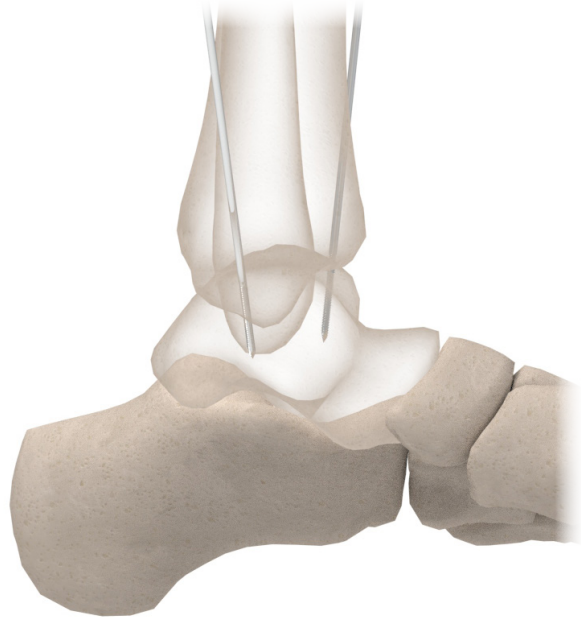

Figure 1b

Patient Positioning

Step One

Place the patient in the supine position on a radiolucent operating table.

Joint Preparation

Step Two

Prepare the joint with preferred technique, open or arthroscopic.

 Note: Bone grafting per surgeon preference.

Temporary Fixation

Step Three

Secure temporary fixation with 2.4mm pins with the joint in optimal position for fusion.

- Neutral flexion
- 0 - 5 degrees of valgus
- 5 - 10 degrees of external rotation

 Note: Optimal pin positioning is posteromedial and anterolateral. (Figure 1a and Figure 1b)

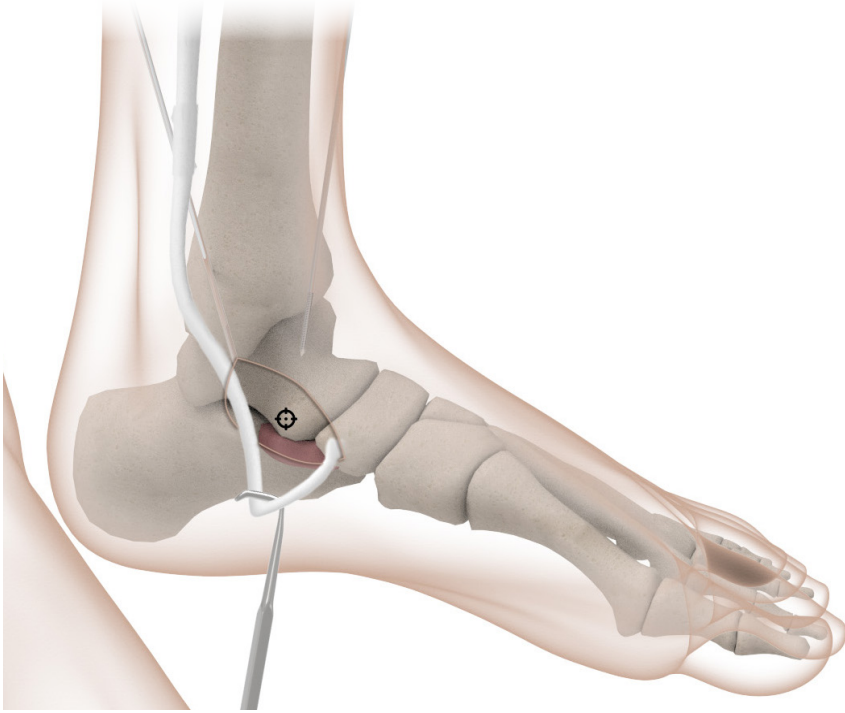

Figure 2

Surgical Approach

Step Four

An incision is made from tip of medial malleolus to navicular tubercle along posterior tibialis tendon. (Figure 2)

Step Five

Retract tendon inferiorly exposing insertion site. The insertion site is just proximal to the articular cartilage of the talar head and just superior to the spring ligament.

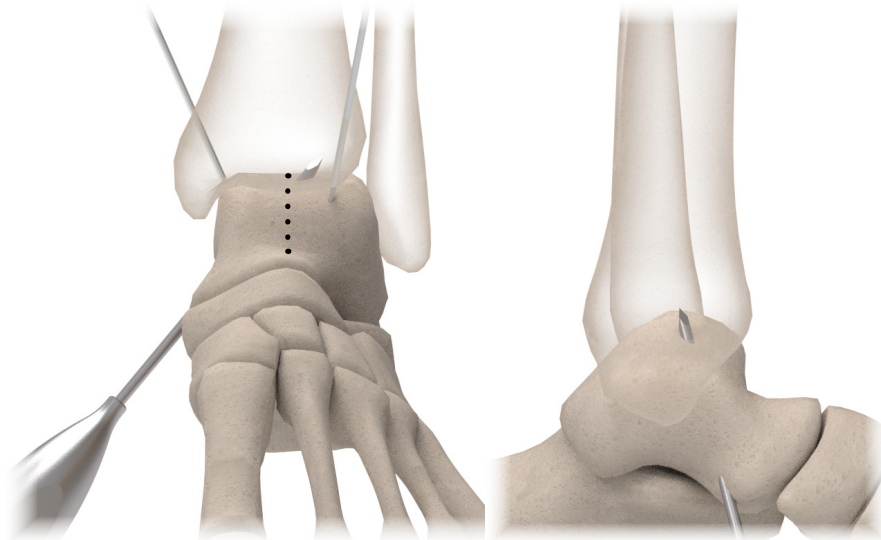

Figure 3a

Figure 3b

Entry Portal Creation

Step Six

Initiate the entry portal at the insertion site using the straight entry awl. Under fluoroscopy, advance the awl aiming superolaterally and slightly posterior to exit the talar dome just lateral to the center on the anterior posterior view (Figure 3a) and in line with the tibia on the lateral view. (Figure 3b)

Alternatively, a drill can be used for this step after an awl creates an entry portal at the insertion site.

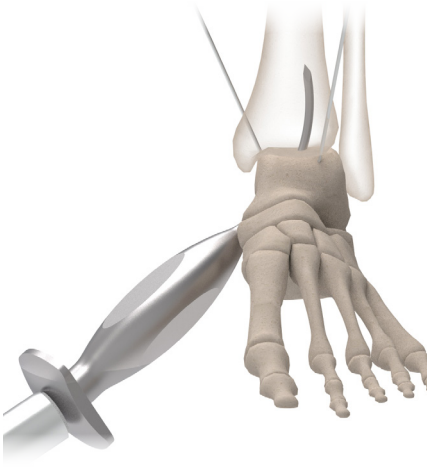

Figure 4a



Figure 4b

Guide Wire Placement and Canal Reaming

Step Seven

Mallet the curved trocar across the joint line into the tibia creating a curved pathway. (Figure 4a and Figure 4b)

 Note: Mallet is not included.

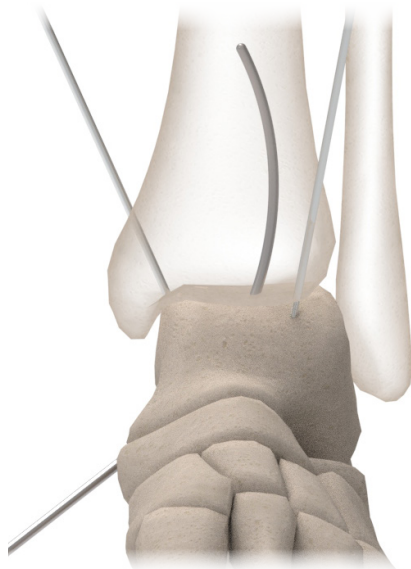

Figure 5a

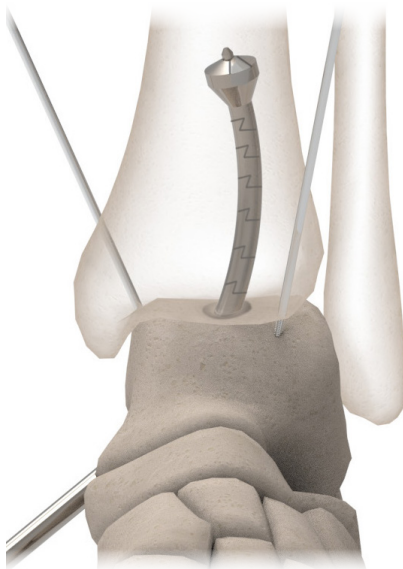

Figure 5b

Step Eight

Insert the rigid stainless steel guide wire into the prepared curved pathway. (Figure 5a)

Step Nine

Enlarge the pathway diameter using the appropriate sized flexible reamer. (Figure 5b)

Nail Insertion

Step Ten

Insert the appropriate size Shotel nail. (Figure 6a)



Note: Adjust the nail depth so that the transarticular screw trajectory is aimed toward the lateral process of the talus. (Figure 6b)

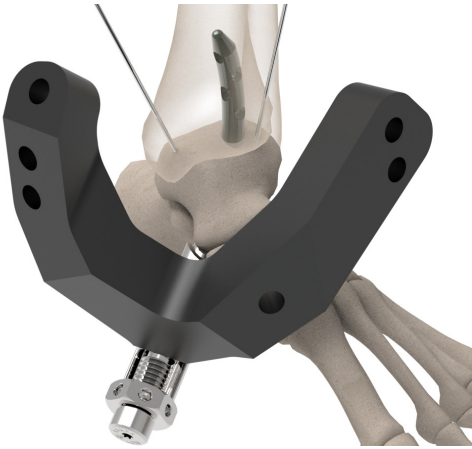

Figure 6a

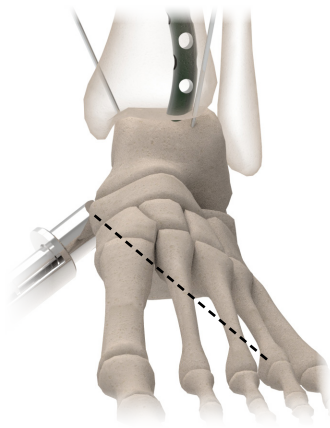

Figure 6b

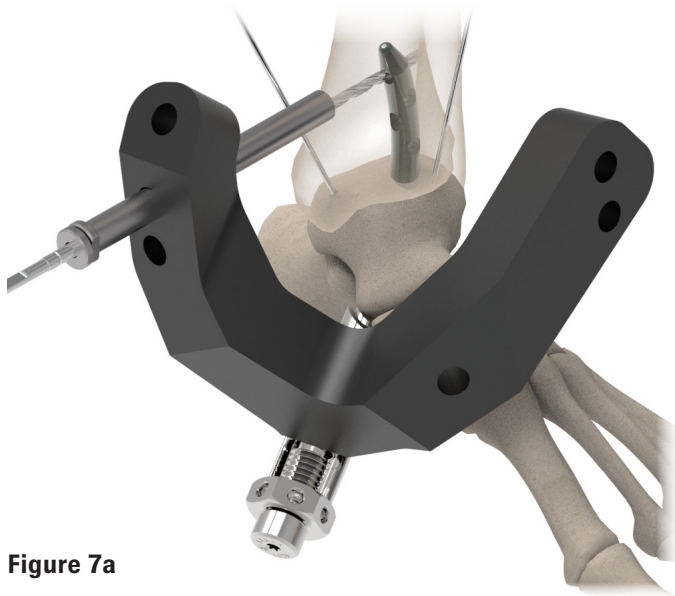

Figure 7a

First Proximal Screw Placement

Step Eleven

Insert the three piece drill sleeve assembly (trocar/drill sleeve/screw sleeve) through the desired hole in the drill guide. Four proximal screw holes are provided. Drill the screw hole to the appropriate depth. (Figure 7a) Measure for the appropriate screw length using either the drill bit markings or depth gauge. (Figure 7b)



Note: Ensure the drill guide locking bolt is securely tightened throughout the drilling, compression, and screw placement steps.

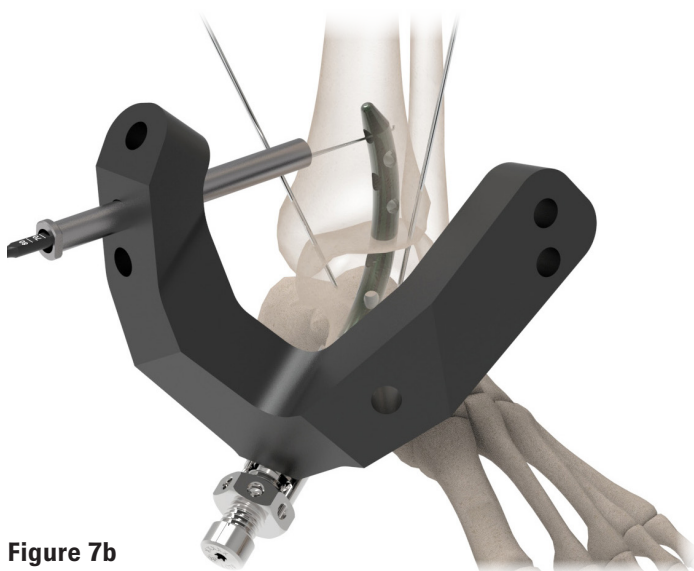

Figure 7b

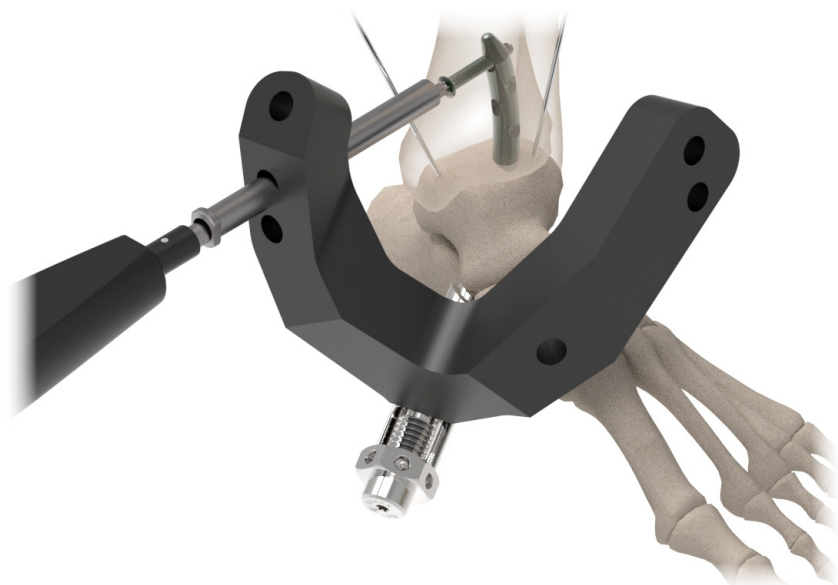

Figure 8

First Proximal Screw Placement

Step Twelve

Place the appropriate length screw through the screw hole. (Figure 8)

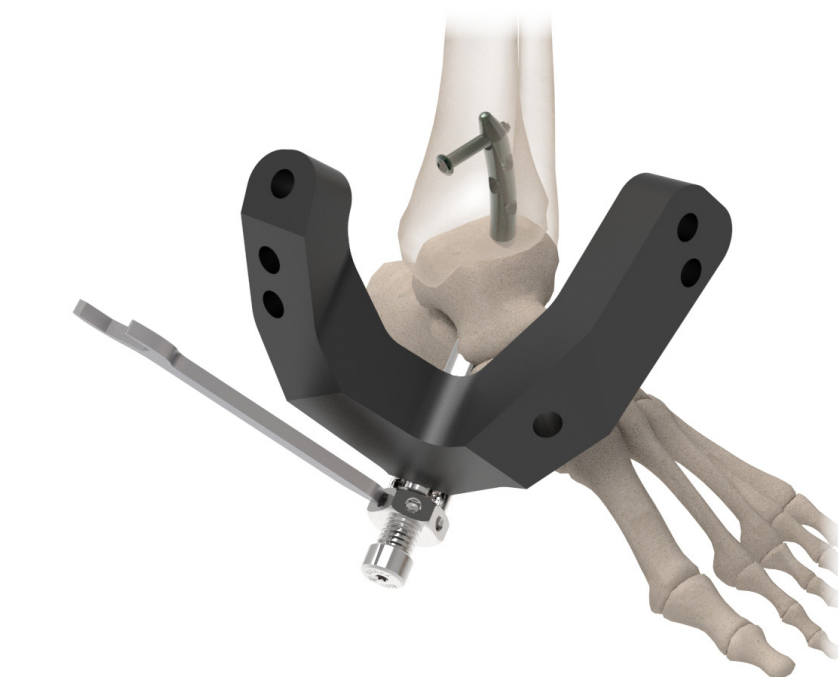

Figure 9

Joint Compression

Step Thirteen

Move compression sleeve into position by hand turning of compression nut.

Step Fourteen

Remove temporary fixation pins.

Step Fifteen

Compress joint with compression sleeve using two finger hand tightening, nut wrench or tommy bar. (Figure 9)

 Note: The amount of achievable compression is bone quality dependent.

 Note: Over-compression may result in loss of fixation, cutout, or subsidence. Care should be taken to avoid bone damage from over-compression.

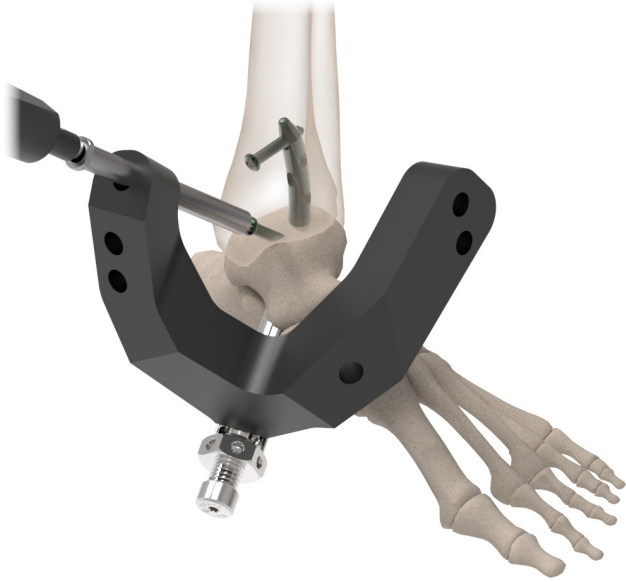

Figure 10

Transarticular Screw Placement

Step Sixteen

Drill, measure and place transarticular screw. (Figure 10)

Talar Screw Placement

Step Seventeen

Drill, measure and place talar screw.

Additional Proximal Screw Placement

Step Eighteen

Drill, measure and place one, two or three additional proximal screw(s).

Nail Cap and Closure

Step Nineteen

Remove compression sleeve and drill guide. Screw on the nail cap. Perform standard wound closure. (Figure 11)

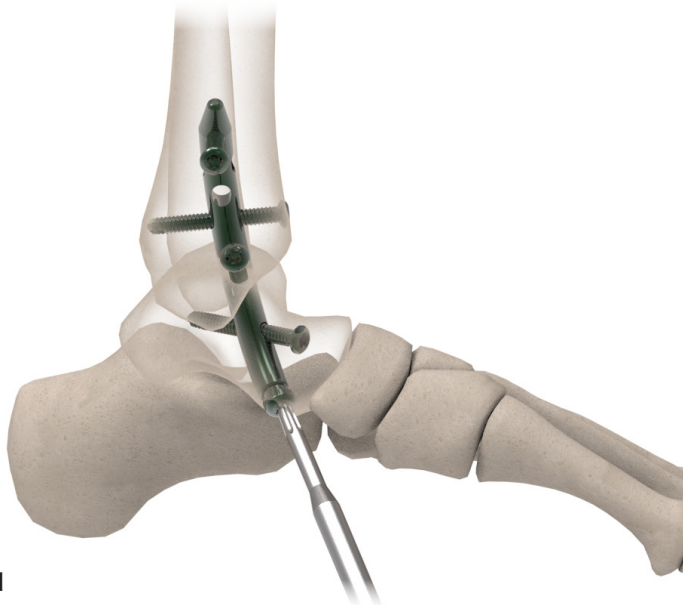

Figure 11

Postoperative X-Rays

The following x-rays are examples of final implant constructs with the utilization of either a 4 or 6 screw construct.



AP View



Lateral View



AP View



Lateral View

Instrument Kit

SHOTEL IMPLANT & INSTRUMENT KIT - 22909

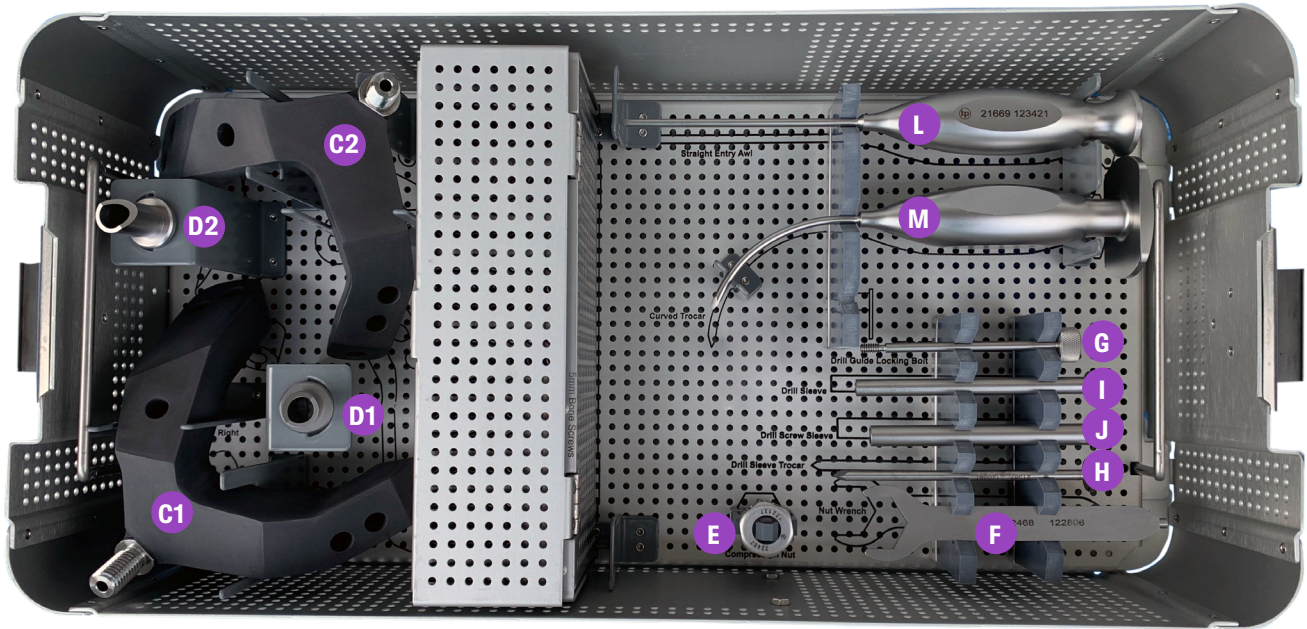

LOCATION	QTY	ITEM #	DESCRIPTION
A1	2	21406	9MM FUSION NAIL LEFT
A2	2	21409	9MM FUSION NAIL RIGHT
B	2	21433	9MM FUSION NAIL CAP
C1	1	22837	DRILL GUIDE, RIGHT-CF
C2	1	22834	DRILL GUIDE, LEFT-CF
D1	1	22840	COMPRESSION SLEEVE, RIGHT-CF
D2	1	22839	COMPRESSION SLEEVE, LEFT-CF
E	1	22467	COMPRESSION NUT
F	1	22468	NUT WRENCH
G	1	22841	DRILL GUIDE LOCKING BOLT-CF
H	1	21387	DRILL SLEEVE TROCAR
I	1	21388	DRILL SCREW SLEEVE
J	1	21658	DRILL SLEEVE
K	1	21390	T25 SCREW DRIVER
L	1	21669	STRAIGHT ENTRY AWL
M	1	22684	CURVED TROCAR
N	1	22411	DEPTH GAGE ASSEMBLY
O	1	22410	DEPTH GAGE BODY

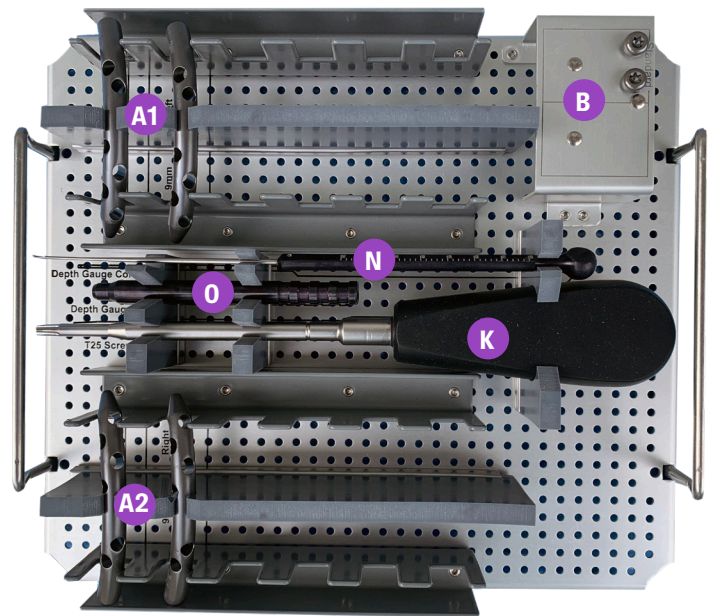



Ordering Information

Fusion Nails

ITEM#	DESCRIPTION	QTY
21406	9MM FUSION NAIL, LEFT	2
21409	9MM FUSION NAIL, RIGHT	2

Nail Caps

ITEM#	DESCRIPTION	QTY
21433	9MM NAIL CAP	2

Bone Screws

ITEM	# DESCRIPTION	QTY
21611	5 MM BONE SCREW X 20 MM	4
21612	5 MM BONE SCREW X 22 MM	4
21613	5 MM BONE SCREW X 24 MM	4
21614	5 MM BONE SCREW X 26 MM	4
21615	5 MM BONE SCREW X 28 MM	4
21352	5 MM BONE SCREW X 30 MM	4
21353	5 MM BONE SCREW X 32 MM	4
21354	5 MM BONE SCREW X 34 MM	4
21355	5 MM BONE SCREW X 36 MM	4
21356	5 MM BONE SCREW X 38 MM	4
21357	5 MM BONE SCREW X 40 MM	4
21358	5 MM BONE SCREW X 42 MM	4
21359	5 MM BONE SCREW X 44 MM	4
21360	5 MM BONE SCREW X 46 MM	4
21361	5 MM BONE SCREW X 48 MM	4
21362	5 MM BONE SCREW X 50 MM	4
21363	5 MM BONE SCREW X 52 MM	4
21364	5 MM BONE SCREW X 54 MM	4
21365	5 MM BONE SCREW X 56 MM	4
21366	5 MM BONE SCREW X 58 MM	4
21367	5 MM BONE SCREW X 60 MM	4
21368	5 MM BONE SCREW X 62 MM	4
21369	5 MM BONE SCREW X 64 MM	4
21370	5 MM BONE SCREW X 66 MM	4
21371	5 MM BONE SCREW X 68 MM	4
21372	5 MM BONE SCREW X 70 MM	4
21616	5 MM BONE SCREW X 72 MM	4
21617	5 MM BONE SCREW X 74 MM	4
21618	5 MM BONE SCREW X 76 MM	4
21619	5 MM BONE SCREW X 78 MM	4
21620	5 MM BONE SCREW X 80 MM	4



Ordering Information

Sterile Packaged Instruments

ITEM #	DESCRIPTION
21674	STEINMANN PIN SINGLE TROCAR ROUND 12" 2.4 MM
22687	CURVED GUIDE WIRE SS
22390	FLEXIBLE REAMER WITH MULTIPLE FLUTE TIP, 10.5 MM
21659	4.2 MM DRILL BIT



www.shotelmedical.com

PATENT 9,782,205 B2

This content is provided as an educational tool only and is not meant as medical advice in the usage of specific BioPro products. A healthcare professional must use their professional judgment in making any final determinations in product usage and technique. The product's Instructions for Use, should always be reviewed prior to surgery. Postoperative management is patient-specific and dependent on the treating professional's assessment. Individual results will vary and not all patients will experience the same postoperative activity level or outcomes. This information does not constitute medical, legal, or any other type of professional advice and should not be relied upon as such. It is not to be redistributed, duplicated, or disclosed without the express written consent of BioPro, Inc.



BioPro, Inc.
2929 Lapeer Road, Port Huron, MI 48060, USA
info@bioproimplants.com | 1-810-982-7777
www.bioproimplants.com

