

# First MTP Fusion Plate

Surgical Technique



# Contents

## **Table of Contents**

Indications & Contraindications	1
Implant Specifications	2-3
Instrument Specifications	4-5
Surgical Technique	6-10
Tray Overview & Ordering	11-17

# Indications & Contraindications

## Indications for use:

The intended use of the BioPro Foot Plating System is to draw two or more aligned bone fragments together to facilitate healing in an adult patient. It is composed of the following bone plate categories:

### I. Forefoot System:

The BioPro Forefoot Plating System is indicated for use in fixation of small bones and small bone fragments in the foot (Phalanges and Metatarsals) for stabilization of fractures, joint fusions, osteotomies, nonunions, malunions, reconstruction of small bones, revision surgeries and replantations in an adult patient. The Forefoot System is not for Spinal Use.

### II. Mid & Hindfoot System:

The BioPro Mid & Hindfoot Plating System is indicated for use in fixation of medium/large bones and medium/large bone multi-fragments in the foot (Cuneiform, Cuboid, Navicular, Talus and Calcaneus) for stabilization of fractures, joint fusions, osteotomies, nonunions, malunions, reconstruction of medium/large bones, revision surgeries and replantations in an adult patient. The Mid & Hindfoot System is not for Spinal Use.

## Contra-indications for use:

1. Infection.
2. Patient conditions including blood supply limitations, obesity and insufficient quantity or quality of bone.
3. Patients with mental or neurologic conditions who are unwilling or incapable of following postoperative care instructions.
4. Foreign body sensitivity. If material sensitivity is suspected, testing is required prior to implanting the device.

## Adverse Effects:

In all surgical procedures, the potential for complications and adverse reactions exist. The risks and complications with these implants include:

- Fracture of the implant due to excessive loading
- Incomplete or inadequate healing
- Implant migration and/or loosening
- Pain, discomfort or abnormal sensations due to the presence of an implant
- Nerve damage resulting from surgical trauma
- Bone necrosis or bone resorption
- Delayed or nonunion of bone fragments
- Allergic reaction to the implant materials

## Warnings & Precautions:

- Re-operation to remove or replace implants may be required at any time due to medical reasons or device failure. If corrective action is not taken, complications may occur.
- Implants which comes in contact with human blood or tissue must not be re-used or re-sterilized.
- Improper insertion of the device during implantation may result in implant loosening or migration.
- Loosening or migration and loss of fixation due to incorrect implantation, delayed union, nonunion and incomplete healing may occur.
- Bending or fracture due to applied excessive stresses and load bearing.
- Failure to follow postoperative care instructions may result in procedure complications or failure.
- Electrolytic action and corrosion due to implanting with other metallic devices of different chemical composition may occur.

## MR Safety Information:

The BioPro Foot Plating System has not been evaluated for safety and compatibility in the MR environment. It has not been tested for heating, migration or image artifact in the MR environment. The safety of the BioPro Foot Plating System in the MR environment is unknown. Scanning a patient who has this device may result in patient injury. Contact surgeon if a change in performance or pain level is noticed.

**WARNING:** Please note that a single use device (SUD) which comes in contact with human blood or tissue should not be re-used and should be returned to the manufacturer or properly disposed. The instrument tray must be wrapped in FDA cleared wraps or containers for the steam sterilization process.

# Implant Specifications

## MTP Fusion Plates

The system offers both standard and revision MTP plates, available in left/right orientation for fusion of the first metatarsophalangeal joint.

The standard construct was designed to act as a neutralization plate in combination with a lag screw across the joint while revision plates feature an oval compression slot for in-line compression as lag screw placement may not be possible.

The standard plates are 1.6mm thick and pre-contoured with 10 degrees of dorsiflexion. The distal cluster allows for the placement of three 2.8mm screws in the narrow phalanx, while the proximal shaft accepts 3.0mm or 3.5mm screws for improved strength.

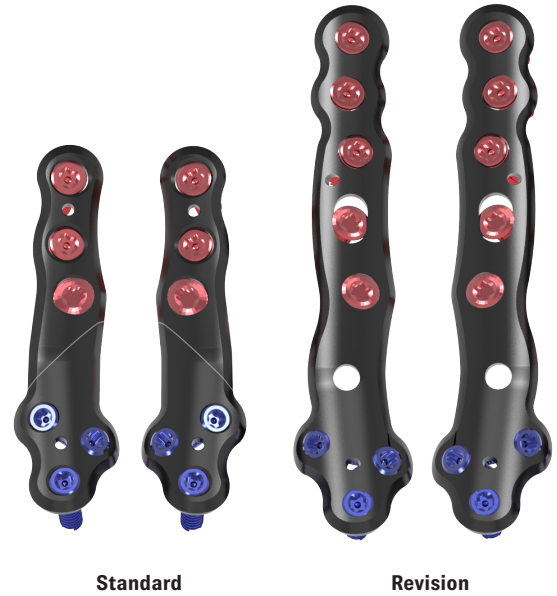

# Implant Specifications



\*Note: Use of a compression screw is recommended but is not required.

# Instrument Specifications

## MTP Joint Reamers

MTP Joint Reamers are available in the MTP module to assist the surgeon in cartilage removal and joint preparation prior to plate placement. The concave (metatarsal head) and convex (phalanx) reamers are available in 16, 18, 21, and 24mm diameters. The reamers feature a 1.7mm cannulation and can be inserted over the provided 1.57mm (.062") k-wires.

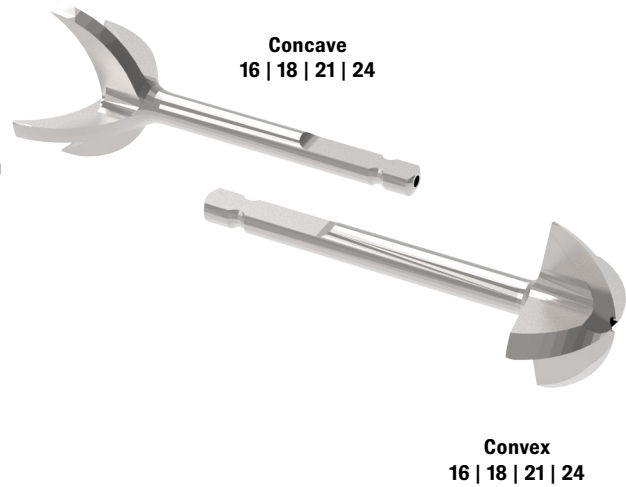

## Drill Guides

The BioPro Foot Plating System offers three standard drill guide types: locking drill guides, MVA drill guides and double drill guides. Each drill guide features color coded dots that coordinate with the drill and screw color.

When inserting a compression non-locking screw, a double drill guide should always be used. Always use an MVA drill guide when drilling at a variable angle.



**Locking Drill Guide**

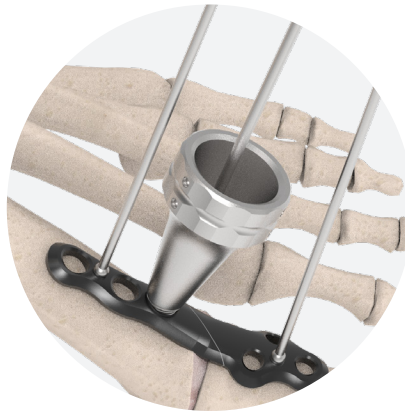

**MVA Drill Guide**



**Double Drill Guide**



# Instrument Specifications

The MTP fusion plate technique requires the following modules from the BioPro Foot Plating System

- Base tray [ref #22925]
- 2.8 Screw Module [ref #22927]
- 3.0/3.5 Screw Module [ref #22928]
- MTP Plate Module [ref #22929]

Note: You may request the 2.8 Plate Module [ref #22930] and the 3.0/3.5 Plate Module [ref #22931] for universal plate options.

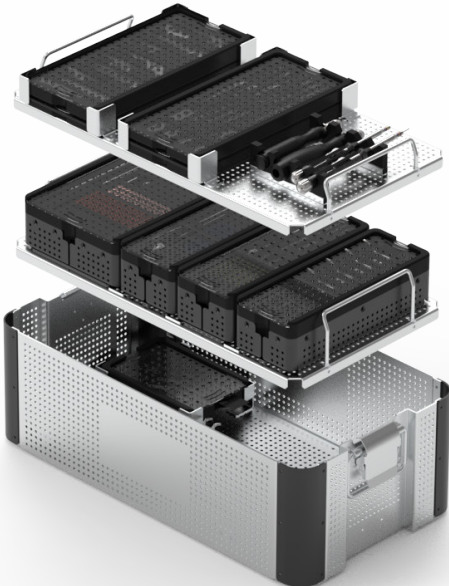

# Surgical Technique



## **Step One:**

Exposure of the first metatarsophalangeal joint is made through a dorsal longitudinal incision. Incise the capsule medial to the extensor hallucis longus tendon, retracting the tendon and exposing the joint.

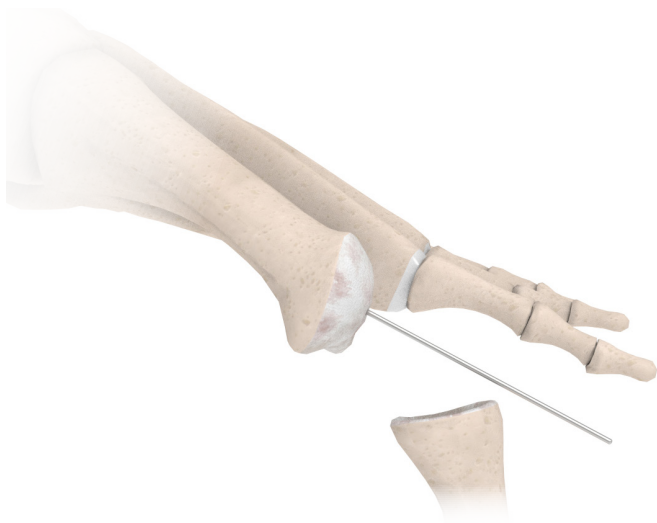

## **Step Two:**

Excise dorsal osteophytes with the preferred method. Sublux the joint in the plantar direction to expose the metatarsal head. Insert a provided 1.57mm (.062") k-wire into the central aspect of the metatarsal.



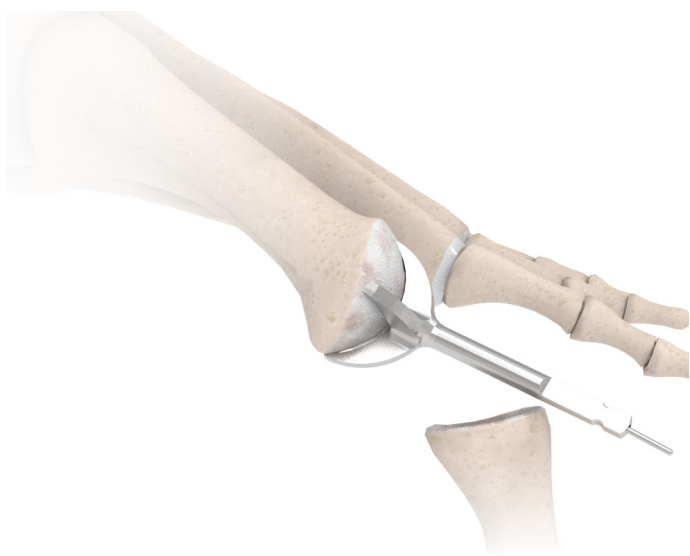

**Step Three:**

Select the appropriately sized (16,18,20,24mm) concave reamer from the set. Use the concave reamer to debride the articular surface of any remaining cartilage from the metatarsal head. Additionally, Subchondral drilling may be performed. After reaming, remove the guide wire from the metatarsal.

**Note:** Take care when reaming, as removing too much bone may result in shorting .



**Step Four:**

Next, insert a 1.57mm (.062") k-wire into the center of the proximal phalanx. Select a convex reamer, using the same diameter as the previous step to debride the articular surface. After reaming is complete, remove the guide wire.



**Step Five:**

Determine the optimal fusion position and insert a k-wire from the proximal phalanx into the metatarsal head.

Note: The plate features a laser line to indicate the insertion angle for a cannulated compression screw. The plate may be placed onto the bone to visualize proper insertion.

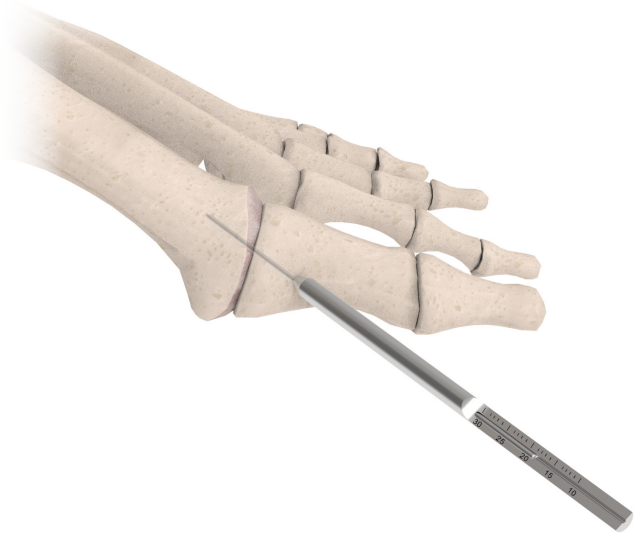

**Step Six:**

Slide the depth gauge over the cannulated screw guide wire and measure to determine proper screw length.



**Step Seven:**

Insert a BioPro headed or headless compression screw over the guide wire and drive to depth.

**Note:** A countersink or relief drill may be used to break the cortex prior to screw insertion.

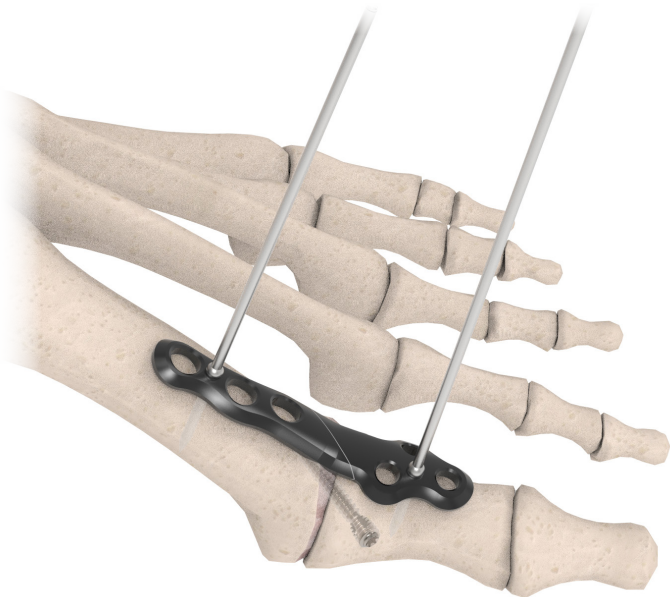

**Step Eight:**

Place the 2.8-3.5mm MTP Fusion Plate onto the dorsal surface and temporarily fixate the plate by inserting the provided olive k-wires into the k-wire holes.

**Note:** The laser engraved line across the plate indicates the insertion angle for the compression screw placement. Ensure this is crossing the joint line.

**Note:** Plate contouring or bone remodeling may be performed to allow the plate to sit flush .

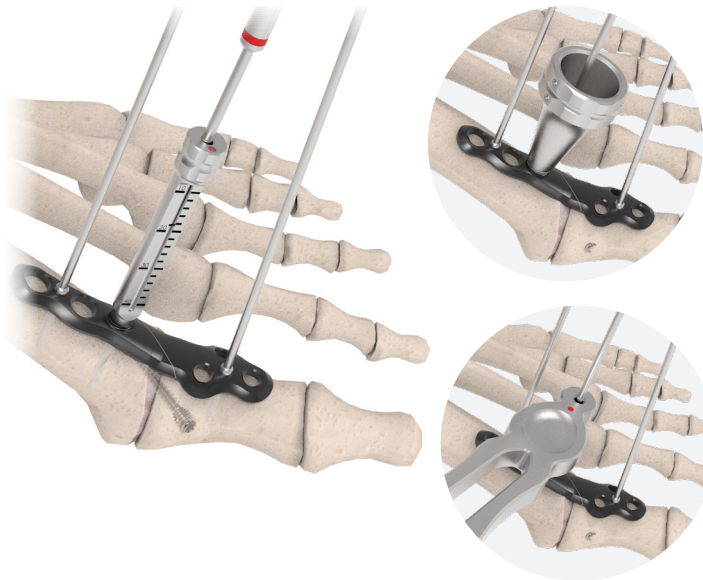

**Step Nine:**

Thread a 3.0mm or 3.5mm locking drill into the distal hole of the metatarsal. After the locking drill guide is locked in place, drill bi-cortically using the 2.0mm (for 3.0mm screws) or 2.5mm (for 3.5mm screws) color-coded (red or orange) drill bit matching the locking drill guide.

**Note:** While the locking drill guide is recommended, the MVA locking drill guide or double drill may also be used.

**Note:** If using the locking drill guide, the appropriate screw length can be determined through the measuring windows in the locking drill guide.

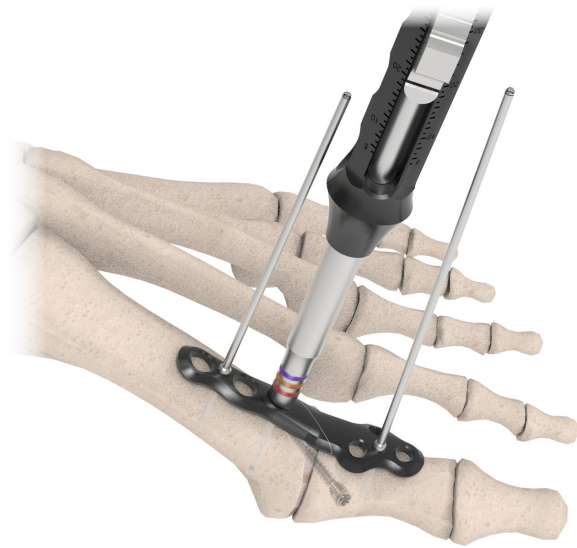

**Step Ten:**

Confirm screw length by inserting the color-coded depth gauge into the drill hole. Expose the wire by sliding the lever back towards you. Hook the wire bi-cortically and slide the lever down until the shaft contacts the plate hole. Measure the screw length by the distal mark.

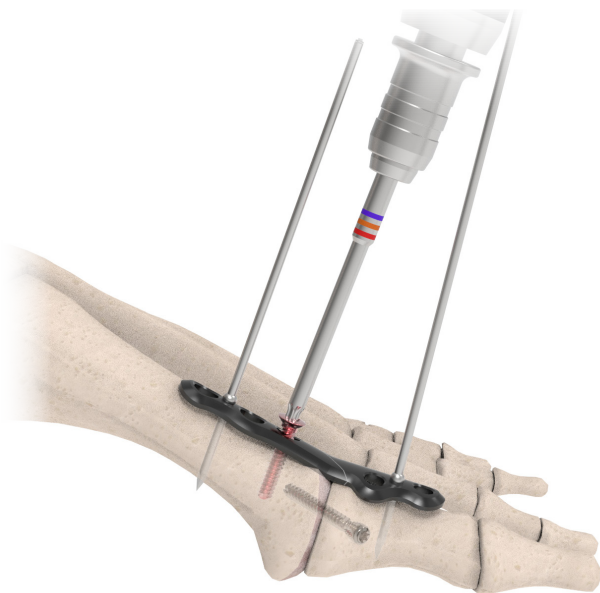

**Step Eleven:**

Insert a 3.0mm or 3.5mm non-locking or MVA locking screw into the screw hole and drive to depth with the color-coded T10 torx driver.

**Note:** A non-locking screw is recommended to compress the plate to the bone.

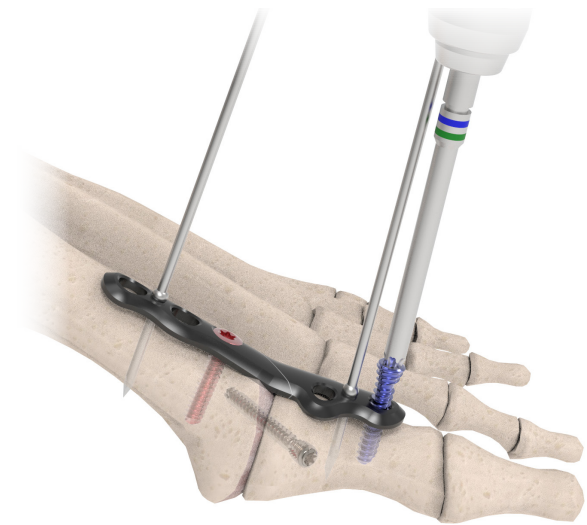

**Step Twelve:**

Repeat the previous drilling and measuring steps, and insert a 2.8mm non-locking or MVA locking screw into the proximal phalanx.



**Step Thirteen:**

Remove the temporarily olive k-wires and fill the remaining screw holes. Wound closure is completed per surgeon's preferred method.

# MTP Plate Module [ref# 22929]

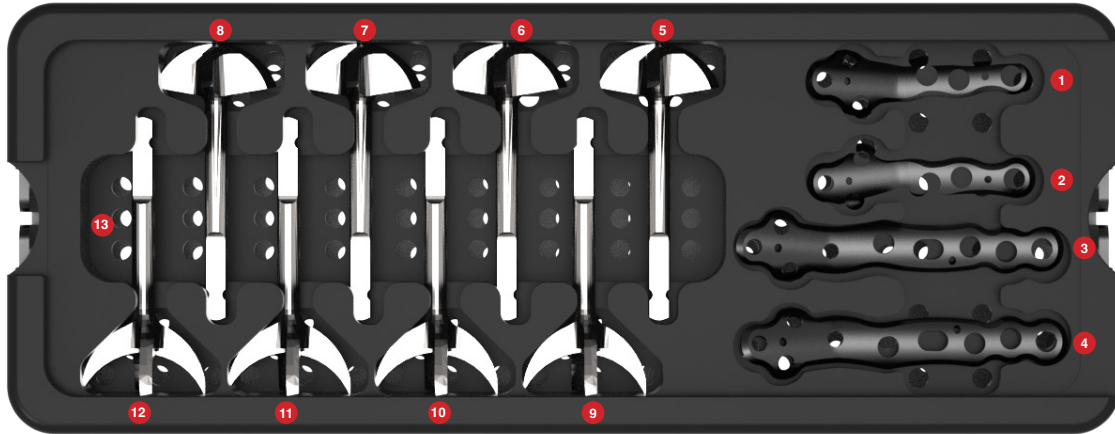

**MTP Plate Module - 22929**

Location	Screw Color	Item #	Description	Qty
1	• • •	20611	MTP Fusion Plate, 2.5-3.5mm, Right	1
2	• • •	20610	MTP Fusion Plate, 2.5-3.5mm, Left	1
3	• • •	20613	MTP Fusion Rev Plate, 2.8-3.5mm, Right	1
4	• • •	20612	MTP Fusion Rev Plate, 2.8-3.5mm, Left	1
5		20671	MTP Fusion Reamer, Convex, 16mm	1
6		20672	MTP Fusion Reamer, Convex, 18mm	1
7		20673	MTP Fusion Reamer, Convex, 21mm	1
8		20674	MTP Fusion Reamer, Convex, 24mm	1
9		20677	MTP Fusion Reamer, Concave, 16mm	1
10		20678	MTP Fusion Reamer, Concave, 18mm	1
11		20679	MTP Fusion Reamer, Concave, 21mm	1
12		20680	MTP Fusion Reamer, Concave, 24mm	1
13		17232	K-Wire .062" x 4" Non-Sterile	4



## 2.8 Screw Module [ref# 22927]

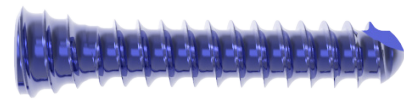
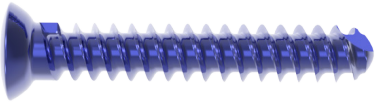
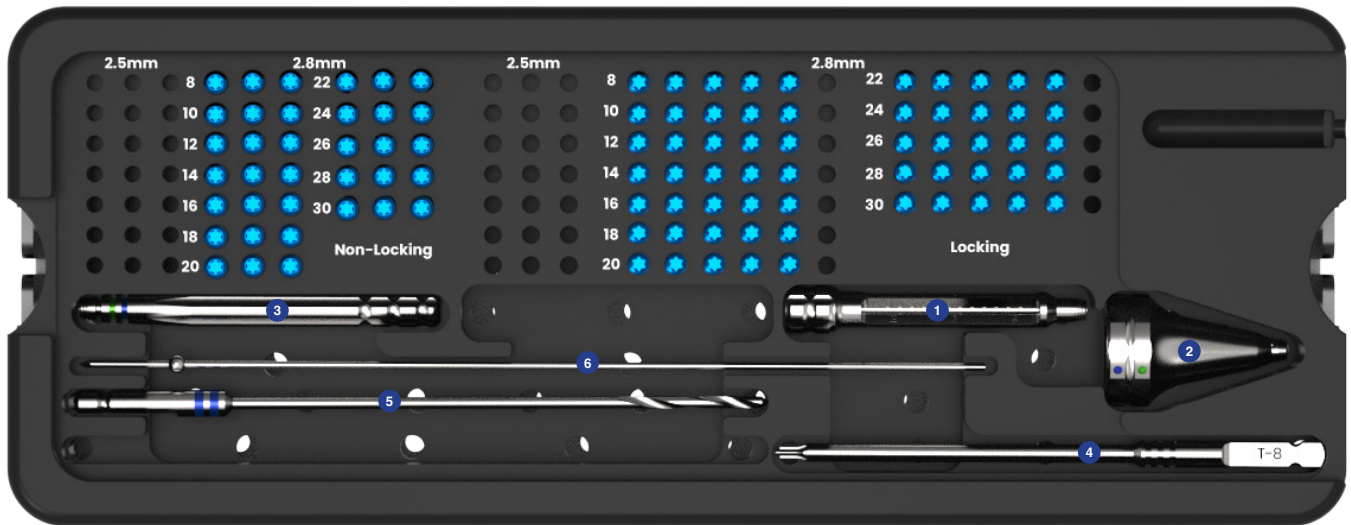

Item #	Description	Qty
20568	Cortical Screw, 2.8mm X 8mm	3
20569	Cortical Screw, 2.8mm X 10mm	3
20570	Cortical Screw, 2.8mm X 12mm	3
20571	Cortical Screw, 2.8mm X 14mm	3
20572	Cortical Screw, 2.8mm X 16mm	3
20573	Cortical Screw, 2.8mm X 18mm	3
20574	Cortical Screw, 2.8mm X 20mm	3
20575	Cortical Screw, 2.8mm X 22mm	3
20576	Cortical Screw, 2.8mm X 24mm	3
20577	Cortical Screw, 2.8mm X 26mm	3
20578	Cortical Screw, 2.8mm X 28mm	3
20579	Cortical Screw, 2.8mm X 30mm	3

Item #	Description	Qty
20556	Cortical Locking Screw, MVA, 2.8mm X 8mm	5
20557	Cortical Locking Screw, MVA, 2.8mm X 10mm	5
20558	Cortical Locking Screw, MVA, 2.8mm X 12mm	5
20559	Cortical Locking Screw, MVA, 2.8mm X 14mm	5
20560	Cortical Locking Screw, MVA, 2.8mm X 16mm	5
20561	Cortical Locking Screw, MVA, 2.8mm X 18mm	5
20562	Cortical Locking Screw, MVA, 2.8mm X 20mm	5
20563	Cortical Locking Screw, MVA, 2.8mm X 22mm	5
20564	Cortical Locking Screw, MVA, 2.8mm X 24mm	5
20565	Cortical Locking Screw, MVA, 2.8mm X 26mm	5
20566	Cortical Locking Screw, MVA, 2.8mm X 28mm	5
20567	Cortical Locking Screw, MVA, 2.8mm X 30mm	5



## 2.8 Screw Module [continued]

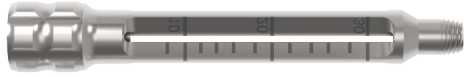

Location	Item #	Description	Qty
1	20638	Locking Drill Guide, 2.8mm	1



Location	Item #	Description	Qty
2	20641	MVA Drill Guide, 2.8mm	1



Location	Item #	Description	Qty
3	20663	Holding & Bending Pin - 2.8mm	2



Location	Item #	Description	Qty
4	20651	Screwdriver Blade - T8	2



Location	Item #	Description	Qty
5	22680	2.0mm x 115mm Drill Bit (Blue)	2



Location	Item #	Description	Qty
6	20940	K-Wire With Stop - 1.2mm	2

# 3.0/3.5 Screw Module [ref# 22928]

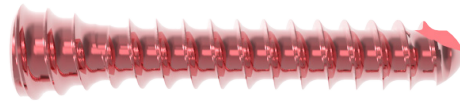
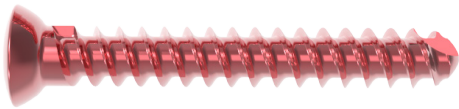
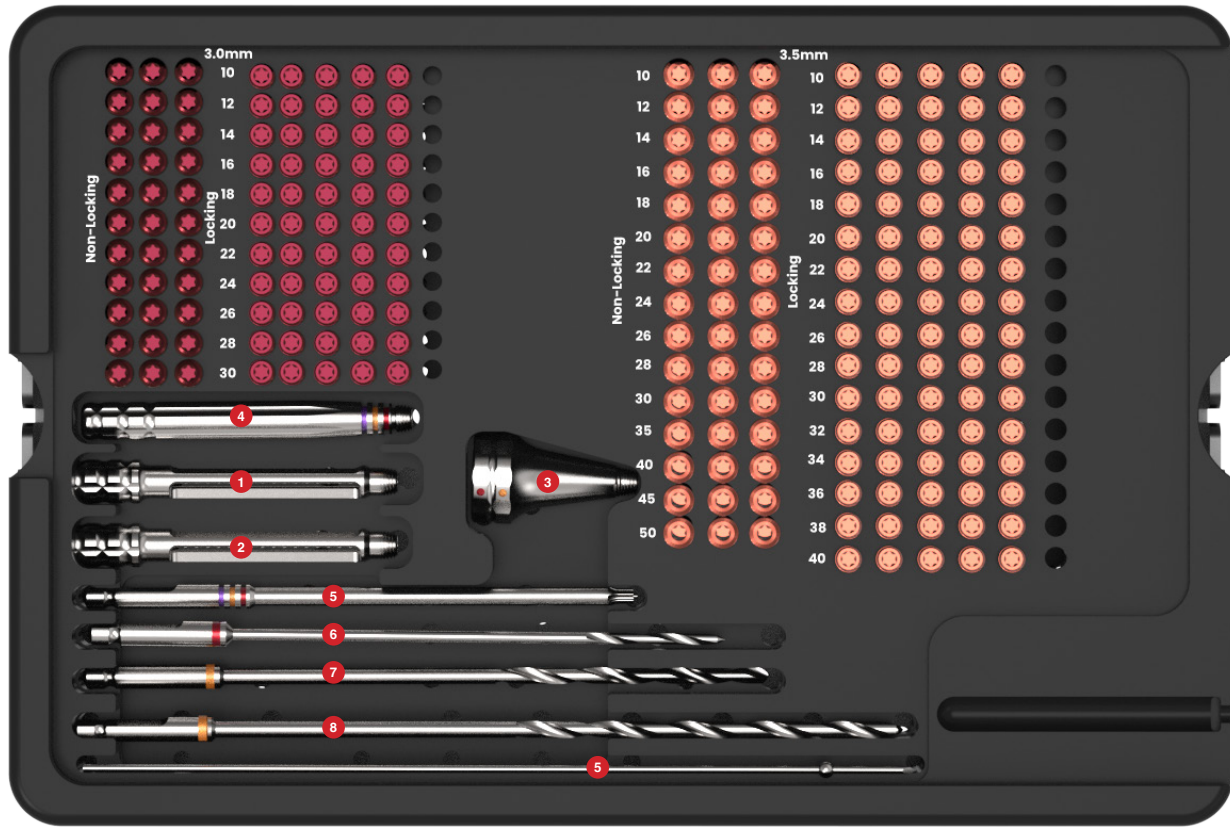

Item #	Description	Qty
20804	Cortical Screw, 3.0mm X 10mm	3
20805	Cortical Screw, 3.0mm X 12mm	3
20806	Cortical Screw, 3.0mm X 14mm	3
20807	Cortical Screw, 3.0mm X 16mm	3
20808	Cortical Screw, 3.0mm X 18mm	3
20809	Cortical Screw, 3.0mm X 20mm	3
20810	Cortical Screw, 3.0mm X 22mm	3
20811	Cortical Screw, 3.0mm X 24mm	3
20812	Cortical Screw, 3.0mm X 26mm	3
20813	Cortical Screw, 3.0mm X 28mm	3
20814	Cortical Screw, 3.0mm X 30mm	3

Item #	Description	Qty
20793	Cortical Locking Screw, MVA, 3.0mm X 10mm	5
20794	Cortical Locking Screw, MVA, 3.0mm X 12mm	5
20795	Cortical Locking Screw, MVA, 3.0mm X 14mm	5
20796	Cortical Locking Screw, MVA, 3.0mm X 16mm	5
20797	Cortical Locking Screw, MVA, 3.0mm X 18mm	5
20798	Cortical Locking Screw, MVA, 3.0mm X 20mm	5
20799	Cortical Locking Screw, MVA, 3.0mm X 22mm	5
20800	Cortical Locking Screw, MVA, 3.0mm X 24mm	5
20801	Cortical Locking Screw, MVA, 3.0mm X 26mm	5
20802	Cortical Locking Screw, MVA, 3.0mm X 28mm	5
20803	Cortical Locking Screw, MVA, 3.0mm X 30mm	5

## 3.0/3.5 Screw Module [continued]

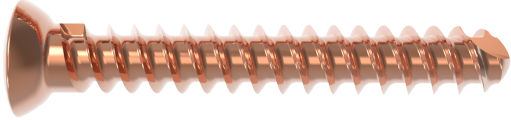

Item #	Description	Qty
21269	Cortical Screw, Low Head, 3.5mm X 10mm	3
21270	Cortical Screw, Low Head, 3.5mm X 12mm	3
21271	Cortical Screw, Low Head, 3.5mm X 14mm	3
21272	Cortical Screw, Low Head, 3.5mm X 16mm	3
21273	Cortical Screw, Low Head, 3.5mm X 18mm	3
21274	Cortical Screw, Low Head, 3.5mm X 20mm	3
21275	Cortical Screw, Low Head, 3.5mm X 22mm	3
21276	Cortical Screw, Low Head, 3.5mm X 24mm	3
21277	Cortical Screw, Low Head, 3.5mm X 26mm	3
21278	Cortical Screw, Low Head, 3.5mm X 28mm	3
21279	Cortical Screw, Low Head, 3.5mm X 30mm	3
21280	Cortical Screw, Low Head, 3.5mm X 35mm	3
21281	Cortical Screw, Low Head, 3.5mm X 40mm	3
21282	Cortical Screw, Low Head, 3.5mm X 45mm	3
21283	Cortical Screw, Low Head, 3.5mm X 50mm	3
21284	Cortical Screw, Low Head, 3.5mm X 55mm	3

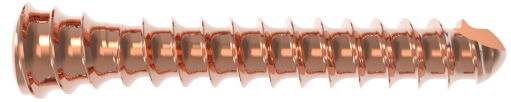

Item #	Description	Qty
20815	Cortical Locking Screw, MVA, 3.5mm X 10mm	5
20816	Cortical Locking Screw, MVA, 3.5mm X 12mm	5
20817	Cortical Locking Screw, MVA, 3.5mm X 14mm	5
20818	Cortical Locking Screw, MVA, 3.5mm X 16mm	5
20819	Cortical Locking Screw, MVA, 3.5mm X 18mm	5
20820	Cortical Locking Screw, MVA, 3.5mm X 20mm	5
20821	Cortical Locking Screw, MVA, 3.5mm X 22mm	5
20822	Cortical Locking Screw, MVA, 3.5mm X 24mm	5
20823	Cortical Locking Screw, MVA, 3.5mm X 26mm	5
20824	Cortical Locking Screw, MVA, 3.5mm X 28mm	5
20825	Cortical Locking Screw, MVA, 3.5mm X 30mm	5
21686	Cortical Locking Screw, MVA, 3.5mm X 32mm	5
21687	Cortical Locking Screw, MVA, 3.5mm X 34mm	5
21688	Cortical Locking Screw, MVA, 3.5mm X 36mm	5
21689	Cortical Locking Screw, MVA, 3.5mm X 38mm	5
20827	Cortical Locking Screw, MVA, 3.5mm X 40mm	5

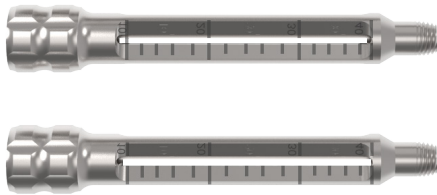

Location	Item #	Description	Qty
1	20917	Locking Drill Guide, 3.0mm	1
2	20918	Locking Drill Guide, 3.5mm	1

Location	Item #	Description	Qty
3	20921	MVA Drill Guide, 3.0-3.5mm	1

## 3.0/3.5 Screw Module [continued]



Location	Item #	Description	Qty
4	20739	Holding & Bending Pin – 3.0/3.5	2



Location	Item #	Description	Qty
5	20929	Screwdriver Blade – T10	2



Location	Item #	Description	Qty
6	20924	2.0mm x 115mm Drill Bit (Red)	2
7	20925	2.5mm x 125mm Drill Bit (Orange)	2
8	20926	2.5mm x 150mm Drill Bit (Orange)	2



Location	Item #	Description	Qty
9	20941	K-Wire With Stop – 1.4mm	2

## Based Tray General Instruments [ref #22925]

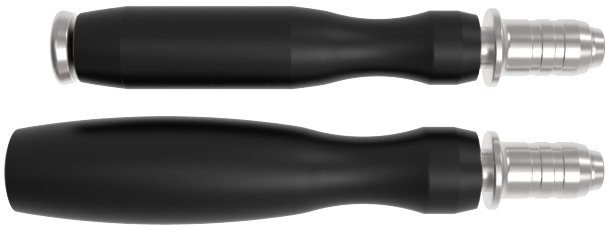

Item #	Description	Qty
20653	Screwdriver Handle – Small	1
20930	Screwdriver Handle – Medium	1



Item #	Description	Qty
20635	Depth Gauge 2.0/2.5/2.8 – 40mm	1
21337	Depth Gauge 3.0/3.5/4.0mm – 50mm	1

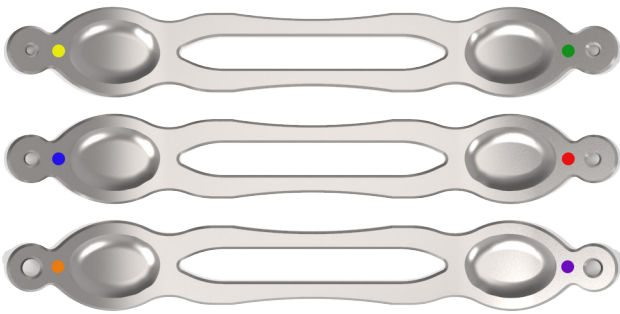

Item #	Description	Qty
20643	Double Drill Guide 2.0-2.5mm Screws	1
20922	Double Drill Guide 2.8-3.0mm Screws	1
20923	Double Drill Guide 3.5-4.0mm Screws	1

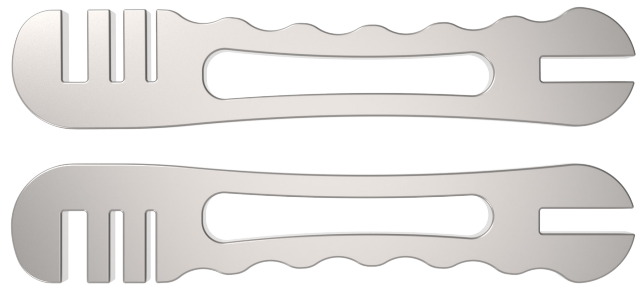

Item #	Description	Qty
20664	Bending Iron – Left	1
20665	Bending Iron – Right	1



Item #	Description	Qty
20934	Hohman Retractor, 8mm	1
20935	Hohman Retractor, 6mm	1

BIOLOGICALLY ORIENTED PROSTHESES  
**BIOPRO**

Call us at 1-810-982-7777 to schedule a case today.

This content is provided as an educational tool only and is not meant as medical advice in the usage of specific BioPro products. A healthcare professional must use their professional judgment in making any final determinations in product usage and technique. The product's Instructions for Use, should always be reviewed prior to surgery. Postoperative management is patient-specific and dependent on the treating professional's assessment. Individual results will vary and not all patients will experience the same postoperative activity level or outcomes. This information does not constitute medical, legal, or any other type of professional advice and should not be relied upon as such. It is not to be redistributed, duplicated, or disclosed without the express written consent of BioPro, Inc.



BioPro, Inc.  
2929 Lapeer Road, Port Huron, MI 48060, USA  
info@bioproimplants.com | 1-810-982-7777  
[www.bioproimplants.com](http://www.bioproimplants.com)

